



# Fire Skids, Trucks, and Equipment

 [www.chemicalcontainers.com](http://www.chemicalcontainers.com) 

-  Nationwide - 1-800-346-7867
-  413 ABC Rd, Lake Wales, Florida 33859
-  Local: (863) 638-1407

# Skids

## 50 GALLON UTV PCO FIRE SUPPRESSION SKID

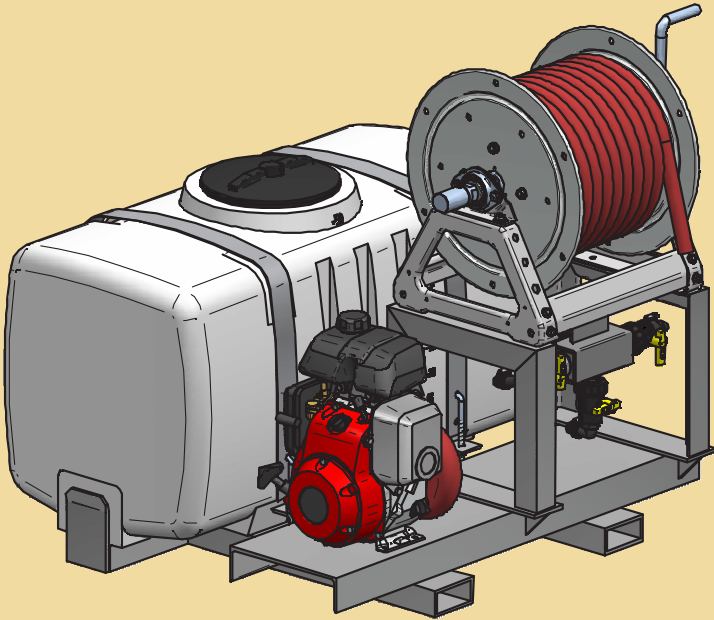

### STANDARD SPECIFICATIONS

- All aluminum frame
- 50 Gallon water tank with easy fill
- Manual Hannay hose reel with hand crank
- 75' of 3/4" red rubber hose with fog nozzle
- Waterax Mini Stryker pump with 2.5hp 4-stroke Honda
- Chemical resistant polyethylene tank with 5 year UV rating
- Factory tested with OEM parts registration

## 50 GALLON UTV ALUMINUM FIRE SUPPRESSION-FORESTRY SKID

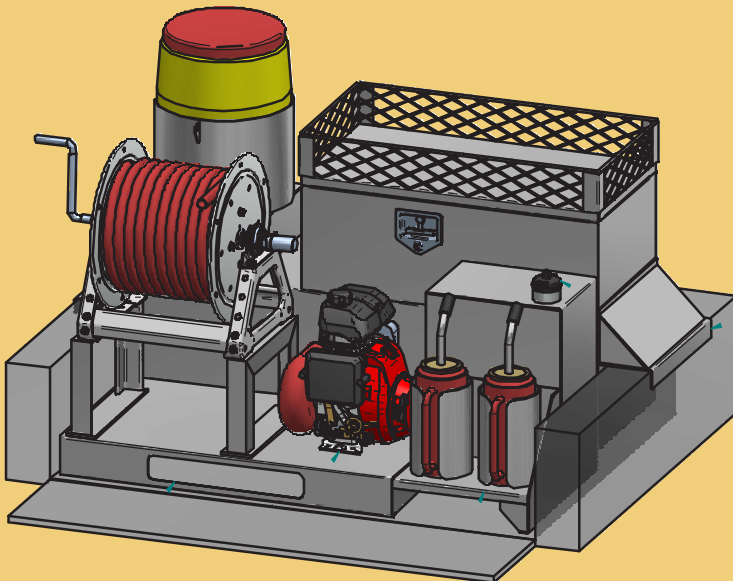

### STANDARD SPECIFICATIONS

- All aluminum frame
- 50 Gallon aluminum tank with easy fill
- Manual Hannay hose reel with hand crank
- 75' of 3/4" red rubber hose
- Waterax Mini Stryker pump with 2.5hp 4-stroke Honda
- (2) Aluminum drip torch holders
- 12 Gallon fuel tank with hose and nozzle
- Water cooler holder
- Aluminum lockbox and storage with gear rack

### OPTIONS

- Brass or stainless steel fittings and valves
- Electric Hannay hose reel
- Custom configurations to allow for larger water capacity



# Skids

## 50-100 GALLON UTV POLY WILDLAND FIRE - RESCUE SKID

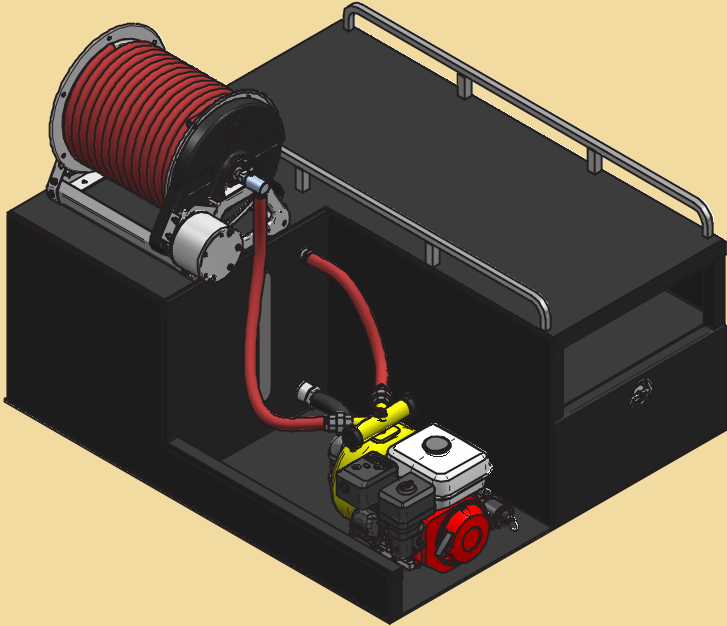

70 GALLON SKID W/ ELECTRIC HOSE REEL SHOWN

### STANDARD SPECIFICATIONS

- 50 Gallon water tank w/ tank level sight tube
- Complete poly welded construction
- Manual Hannay hose reel with hand crank, 1" x 50' hose
- Darley AK 302 single impeller pump
- 5.5 hp manual start Honda engine, 39-90 PSI, 20-95 GPM
- 1" NHT discharge w/ full port brass ball valve, cap, and chain
- 1-1/2" NHT discharge w/ full port brass ball valve, cap, and chain
- 1" discharge to hose reel w/ full port brass ball valve
- 1" recirculate w/ full port brass valve
- 1-1/2" tank to pump suction

### OPTIONS

- 70 Gallon water capacity
- 100 Gallon water capacity
- Darley AK 314 twin impeller pump, 6.5 hp Honda electric start
- 1" x 50' NFPA booster hose
- 1" x 100' NFPA booster hose
- Hannay electric rewind hose reel

## 50-100 GALLON UTV ALUMINUM WILDLAND FIRE - RESCUE SKID

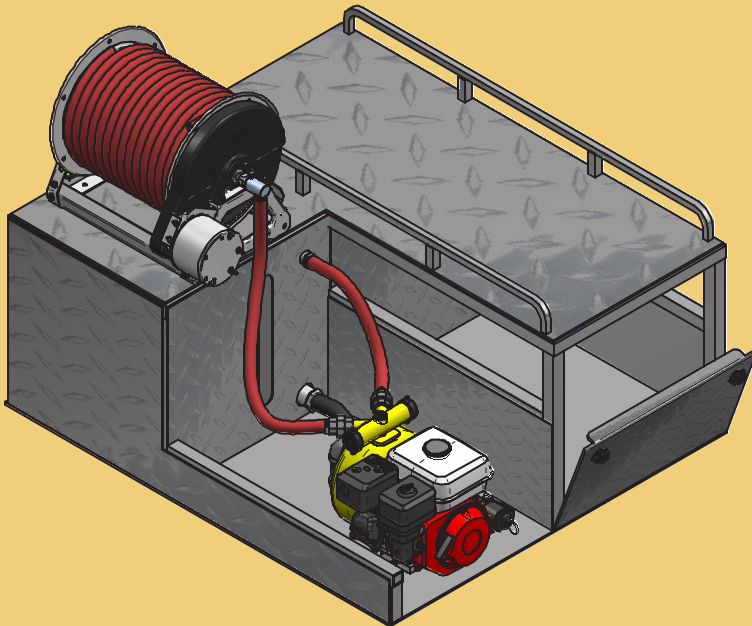

70 GALLON SKID W/ ELECTRIC HOSE REEL SHOWN

### STANDARD SPECIFICATIONS

- 50 Gallon water tank w/ tank level sight tube
- Complete aluminum welded construction
- Manual Hannay hose reel with hand crank, 1" x 50' hose
- Darley AK 302 single impeller pump
- 5.5 hp manual start Honda engine, 39-90 PSI, 20-95 GPM
- 1" NHT discharge w/ full port brass ball valve, cap, and chain
- 1-1/2" NHT discharge w/ full port brass ball valve, cap, and chain
- 1" discharge to hose reel w/ full port brass ball valve
- 1" recirculate w/ full port brass valve
- 1-1/2" tank to pump suction

### OPTIONS

- 70 Gallon water capacity
- 100 Gallon water capacity
- Darley AK 314 twin impeller pump, 6.5 hp Honda electric start
- 1" x 50' NFPA booster hose
- 1" x 100' NFPA booster hose
- Hannay electric rewind hose reel



# Skids

## 75-100 GALLON UTV POLY WILDLAND FIRE SKID

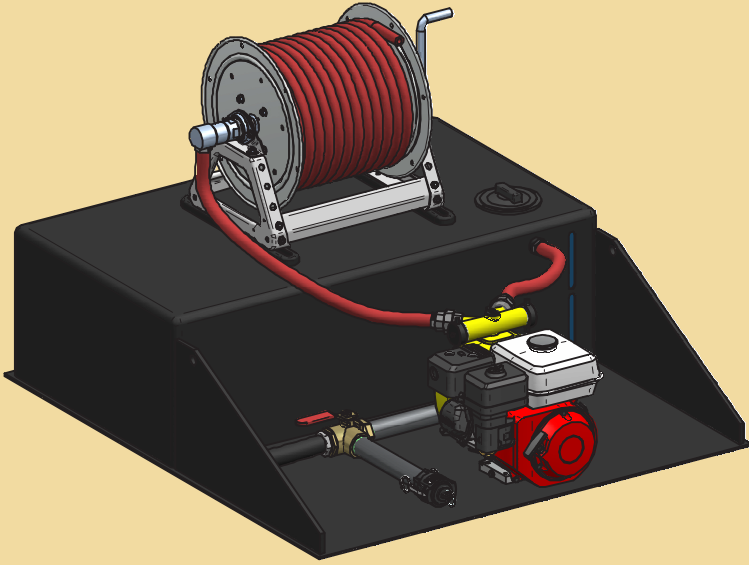

75 GALLON SKID SHOWN

### STANDARD SPECIFICATIONS

- 75 Gallon water tank w/ tank level sight tube
- Complete poly-welded construction
- Manual Hannay hose reel with hand crank, 1" x 50' hose
- Darley AK 302 single impeller pump
- 5.5 hp manual start Honda engine, 39-90 PSI, 20-95 GPM
- 1" NHT discharge w/ full port brass ball valve, cap, and chain
- 1-1/2" NHT discharge w/ full port brass ball valve, cap, and chain
- 1" discharge to hose reel w/ full port brass ball valve
- 1" recirculate w/ full brass port valve
- 1-1/2" tank to pump suction

### OPTIONS

- 100 Gallon water capacity
- Darley AK 314 twin impeller pump, 6.5 hp Honda electric start
- 1" x 50' NFPA booster hose
- 1" x 100' NFPA booster hose
- Hannay electric rewind hose reel

## 100-500 GALLON POLY WILDLAND PICKUP-FLATBED SKID

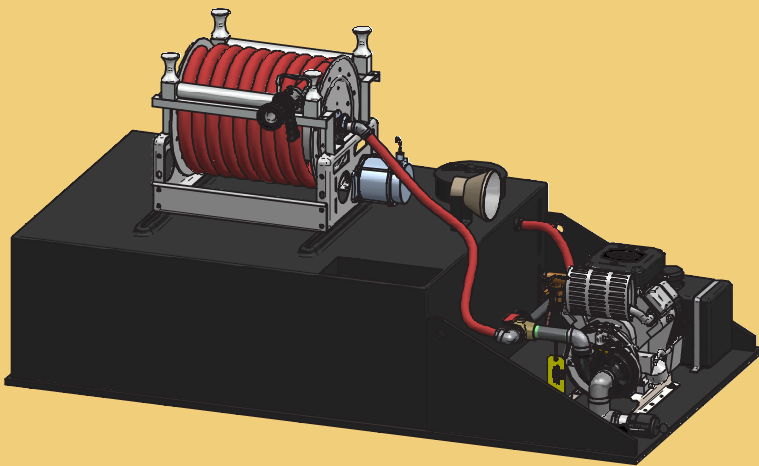

200 GALLON SKID SHOWN

### STANDARD SPECIFICATIONS

- 100 Gallon water tank w/ tank level sight tube
- Complete poly-welded construction
- Electric Hannay hose reel, 1" x 100' hose
- Darley AK 314 twin impeller pump
- 6.5 hp electric start Honda engine, 48-120 PSI, 20-65 GPM
- 1" NHT discharge w/ full port brass ball valve, cap, and chain
- 1-1/2" NHT discharge w/ full port brass ball valve, cap, and chain
- 1" discharge to hose reel w/ full port brass ball valve
- 1" recirculate w/ full brass port valve, 1-1/2" tank to pump suction

### OPTIONS

- 200, 300, 400, and 500 Gallon Tanks
- Built-in foam cell
- Hale HPX200-B18 Pump w/ 18 HP Briggs & Stratton, 175 PSI/245 GPM w/ remote Hale control panel and primer
- 1" x 100' NFPA Booster Hose, 800 PSI
- Scotty 4171 foam system
- Custom stainless discharge manifold





# Skids



# Brush Trucks

## STANDARD SPECIFICATIONS

- 400 Gallon Pro Poly Tank w/ 12 gallon foam cell and water level monitor
- Hale HPX200-B18 ump w/ 18 HP Briggs & Stratton, 175 PSI/245 GPM w/ rear and cab mounted Hale control panel
- Scotty 4171 Foam Proportioner with rear mounted control
- Electric Hannay hose reel, 150' of 1" booster hose and Viper Fog Nozzle
- Front mounted ground sweep system with electronic valves and in cab controls
- Front mounted Task Force EF1 monitor with in cab joystick control
- All stainless steel plumbing with heavy duty fire service valves and function labeling
- Heavy duty aluminum bed with headache rack
- Under bed storage boxes and compartments with lighting
- Top hinged side storage boxes with lift assist and lighting
- Gear storage racks on top of side storage boxes
- HD rear bumper w/ 2" receiver, trailer wiring and tow hooks
- Rear folding steps
- Custom stainless discharge manifold
- 2-1/2" FNPT to pump discharge
- 1" FNPT to tank recycle/fill
- 1" to FNPT to hose reel
- 1-1/2" FNPT to quick attack hose line
- (2) 2-1/2" intake and tank to pump valves
- Rear mounted work light and complete control panel with water level and PSI gauge and pump, motor and foam controls
- In-cab console with pump controls, siren/light controller, RC monitor controller, ground sweep controller, with accommodation for fire service radio and low-voltage warming system
- Full NFPA 1906 reflective decal package
- Federal FR7-RW emergency lights
- Oval led stop lights, tail lights and backup lights
- Allegiant emergency light bar, dual color micropulse warning lights and Federal speaker with cab console mounted controls

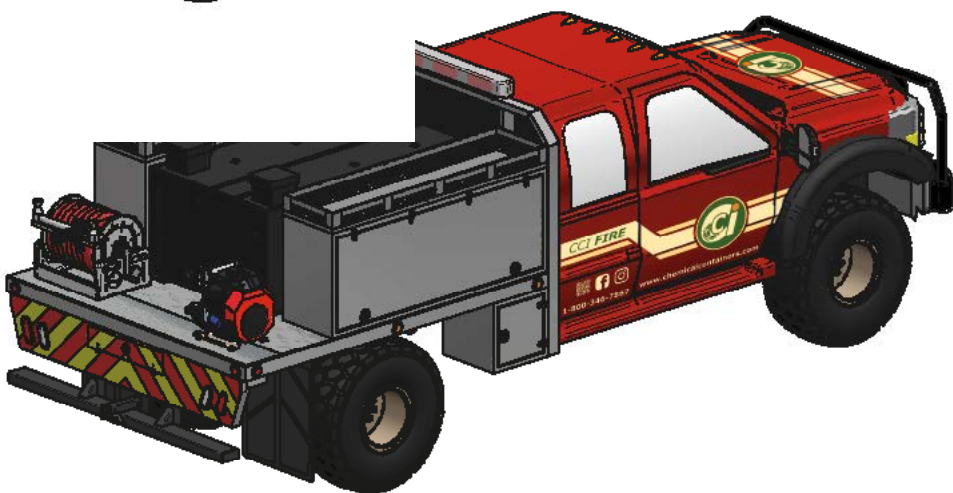
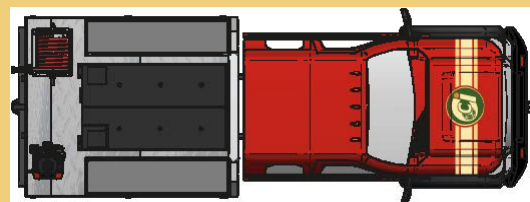



# Brush Trucks



## OPTIONS AND FEATURES:

- BRUSH GUARDS
- SKID PLATES
- INTERIOR CONSOLES
- INTERIOR CONTROL PANELS
- PULL-OUT TRAYS
- SCBA STORAGE
- FRONT BUMPER HOSE
- BED HAND RAILS
- HEAVY DUTY BUMPERS
- FRONT MOUNTED FIRE MONITORS
- LIFT KITS
- FOAM SYSTEMS AND TANKS
- LIGHT TOWERS
- EMERGENCY VEHICLE LIGHTING
- GROUND LIGHTS
- GO LIGHTS
- COMPARTMENT LIGHTS
- RADIO/ANTENNA INSTALLATION
- SITCOM/FIRECOM INSTALLATION
- GENERATORS
- TOOLS
- TOOL BOXES
- TOOL MOUNTING
- FIRE EXTINGUISHERS
- WINCHES
- SUPER SINGLE WHEEL CONVERSIONS



# SIZE REALLY DOES MATTER!

IF YOU WANT THE BEST SERVICE AND VALUE.

WE HAVE OVER 64,000 SQ FT OF MANUFACTURING AND WAREHOUSE SPACE WITH 18 ACRES OF FACILITIES. THIS ALLOWS US TO BUILD YOUR EQUIPMENT FASTER AND SHIP YOU PARTS THE SAME DAY.



- YOU WANT IT, WE GOT IT! WITH OVER 15,000 ITEMS IN STOCK, YOUR ORDER IS READY TO SHIP TODAY.
- TELL US WHAT YOU NEED AND WE CAN CUSTOMIZE ANY PIECE OF EQUIPMENT TO SUIT YOUR NEEDS.
- EMERGENCY! SAME DAY DELIVERY ON PARTS AVAILABLE.
- MOBILE SALES PEOPLE PROVIDE YOU WITH ON-SITE SERVICE FOR YOUR COMPANY'S NEEDS.

- CUSTOM CAD DESIGNS FOR EQUIPMENT AND LIQUID HANDLING SYSTEMS.
- SPECIALTY WELDING OF STAINLESS STEEL, ALUMINUM, AND POLYETHYLENE.
- COMPLETE SERVICE, REPAIRS AND MAINTENANCE



“Specialists In Liquid Handling Products & Equipment”

413 ABC Rd. • Lake Wales, Fl. 33853

Sales 800-346-7867 • Fax 863-638-1863

[www.chemicalcontainers.com](http://www.chemicalcontainers.com)